

Powerful, Easy, Versatile Drive **iMaster C1**

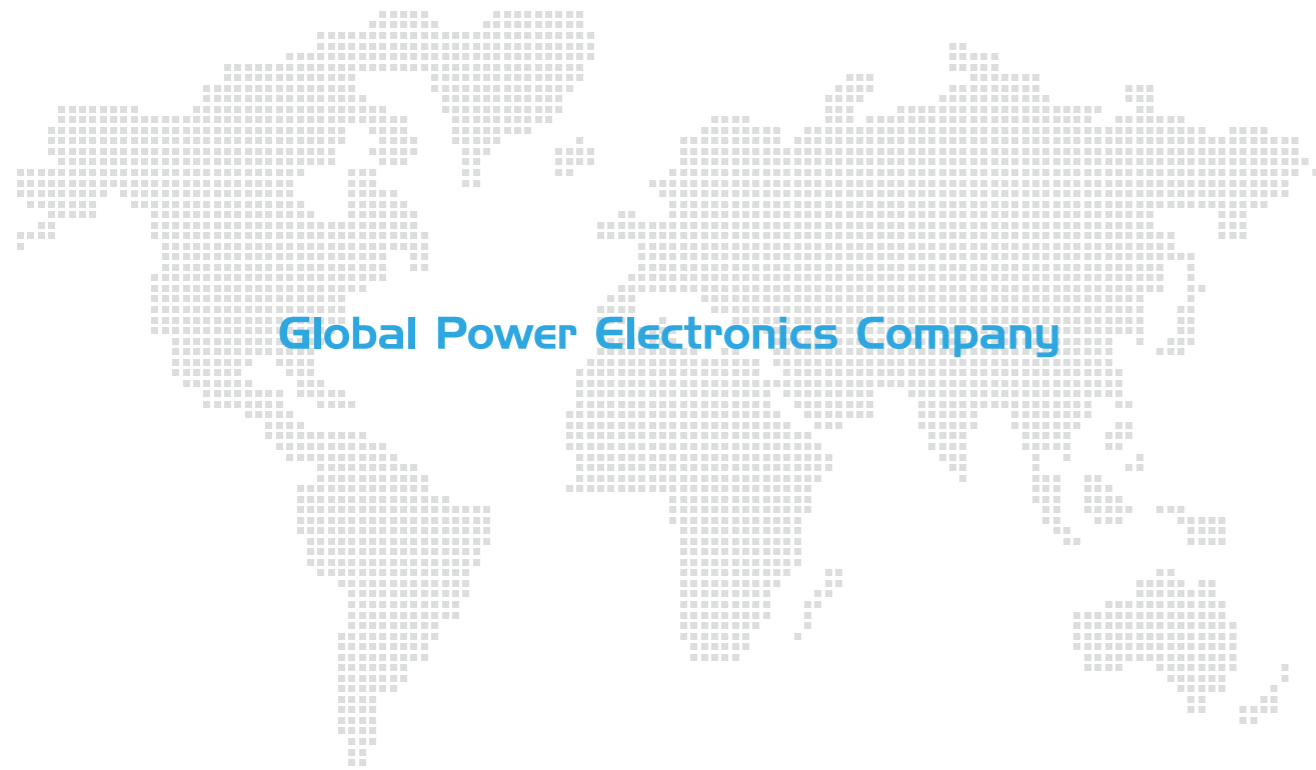

Powerful, Easy Versatile Drive

iMASTER C1

AD Advanced Drive Technology
motor control & power conversion

www.adtech21.com

ADT Co., LTD
Headoffice/Factory

#56, Beolmal-ro, Dongan-gu, Anyang-si, Gyeonggi-do, 14059 KOREA
Tel: +82-31-459-5051 Fax: +82-31-459-5053 email: service@adtech21.com



Specifications of the product are subject to change without notice for quality improvement.

Printed in Korea

AD Advanced Drive Technology
motor control & power conversion

Versatile Compact Drive

iMASTER C1

iMaster C1's compact size and sensorless vector control technology provide optimized performance for industrial equipment.

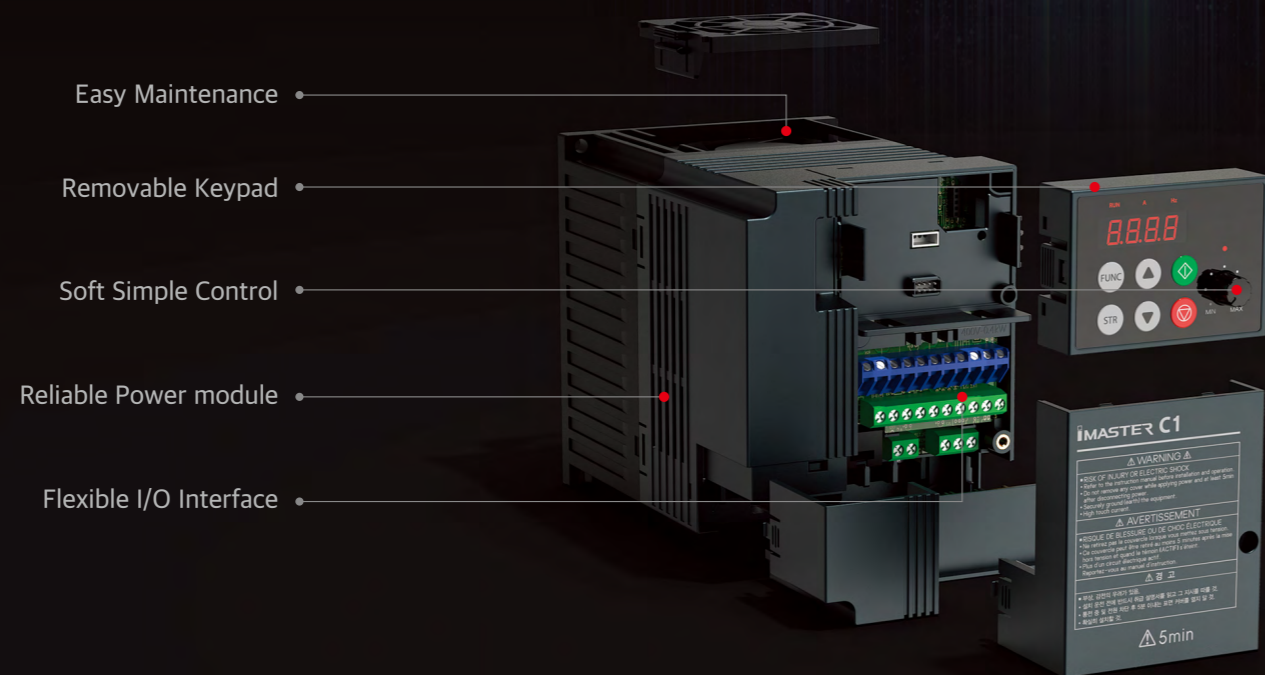

- Easy Maintenance
- Removable Keypad
- Soft Simple Control
- Reliable Power module
- Flexible I/O Interface

Product Range

- 1 Phase 220V 0.4kW ~ 2.2kW
- 3Phase 220V 0.4kW ~ 15kW
- 3Phase 440V 0.4kW ~ 160kW

High Performance

- V/F, User V/F, Enhanced Sensorless Vector control
- Dual Rating (Heavy Duty & Normal Duty)
- High Torque at low speed (150% @ 1 Hz)
- Built-in EMC Filter (Optional, 5.5~22kW)

Excellent Applicability

- KEB Function
- External Brake Control (for Lift, Hoist)
- Automatic current suppression function (Minimization of inverter stop)
- Adoption of optimal algorithm to minimize the motor loss
- Robust control of PM synchronous motor

Easy, Simple, User friendly Options

- Removable Keypad
- Side by Side Installation
- Built-in Fieldbus communication (Optional)
- Built-in Encoder card (Optional)
- Easy Installation & Simple Operation

■ Specifications (0.4kW~22kW)

Applied Motor		1Phase 220V (200~240V, ±10%, 50/60Hz)			3Phase 220V (200~240V, ±10%, 50/60Hz)			3Phase 440V (380~480V, ±10%, 50/60Hz)		
kW	HP	Frame	Model	A	Frame	Model	A	Frame	Model	A
0.4	0.5	F1	004SF	2.8 (3.2)	F1	004LF	2.8 (3.2)	F2	004HF	1.5 (1.8)
0.75	1	F1	007SF	4.8 (5.0)	F1	007LF	4.8 (5.0)	F2	007HF	2.7 (3.4)
1.5	2	F2	015SF	7.5 (8.5)	F1	015LF	7.5 (8.5)	F2	015HF	4.2 (4.8)
2.2	3	F2	022SF	11.0 (12.5)	F2	022LF	11.0 (12.5)	F2	022HF	5.5 (7.2)
3.7	5				F3	037LF	17.0 (19.5)	F3	037HF	9.0 (10.5)
5.5	7.5				F4	055LF	25 (30)	F4	055HF	14.8 (17.5)
7.5	10				F4	075LF	33 (40)	F4	075HF	18 (23)
11	15				F5	110LF	47 (56)	F5	110HF	24 (31)
15	20				F6	150LF	64 (73)	F5	150HF	32 (38)
18.5	25							F6	185HF	39 (44)
22	30							F6	220HF	45 (58)

■ Dimension

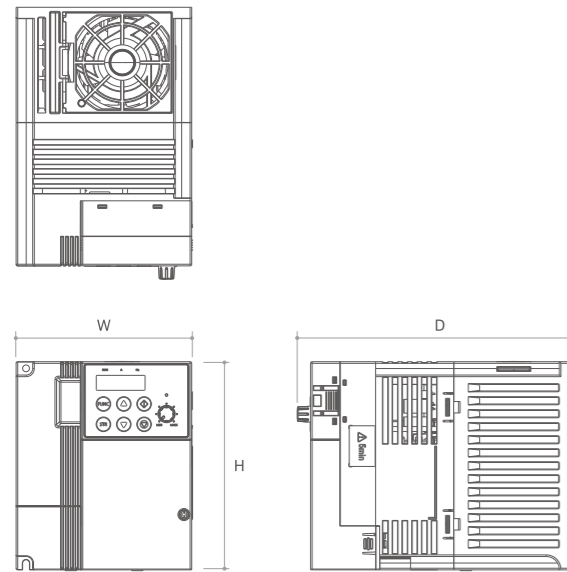

Frame	F1	F2	F3
W [mm]	68	108	140
H [mm]	128	128	128
D [mm]	160	167	172
Weight [kg]	0.8	1.0	1.3

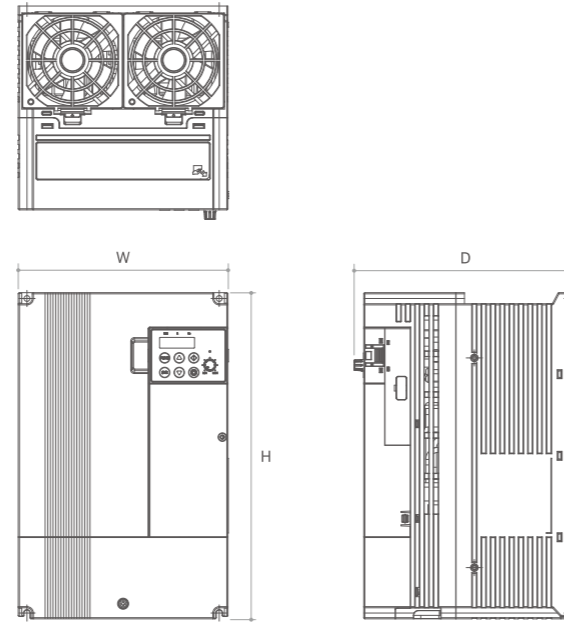

Frame	F4	F5	F6
W [mm]	160	180	220
H [mm]	230	280	315
D [mm]	183	183	193
Weight [kg]	2.8	4.1	6.1

■ Specifications (30kW~160kW)

Applied Motor		3Phase 440V (380~480V, ±10%, 50/60Hz)		
kW	HP	Frame	Model	A
30	40	F7	300HF	61 (71)
37	50	F7	370HF	75 (86)
45	60	F8	450HF	91 (102)
55	75	F8	550HF	110 (135)
75	100	F9	750HF	149 (160)
90	125	F9	900HF	176 (194)
110	150	F10	1100HF	217 (231)
132	200	F10	1320HF	260 (277)
160	250	F10	1600HF	300 (324)

■ Dimension

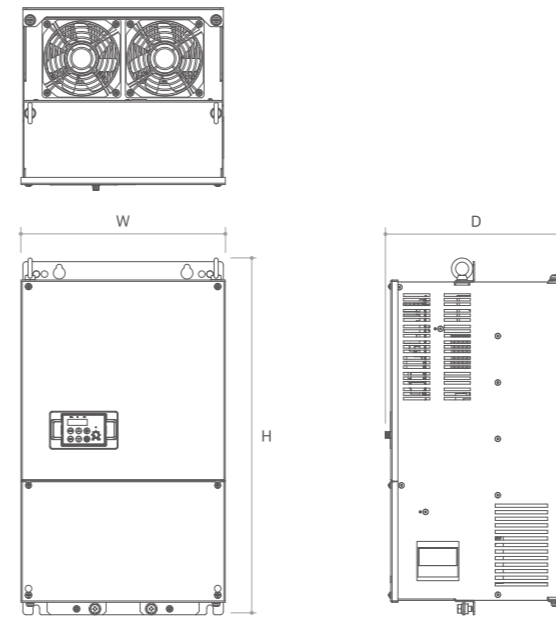

Frame	F7	F8
W [mm]	312	342
H [mm]	539	554
D [mm]	278	288
Weight [kg]	22.4	28.4

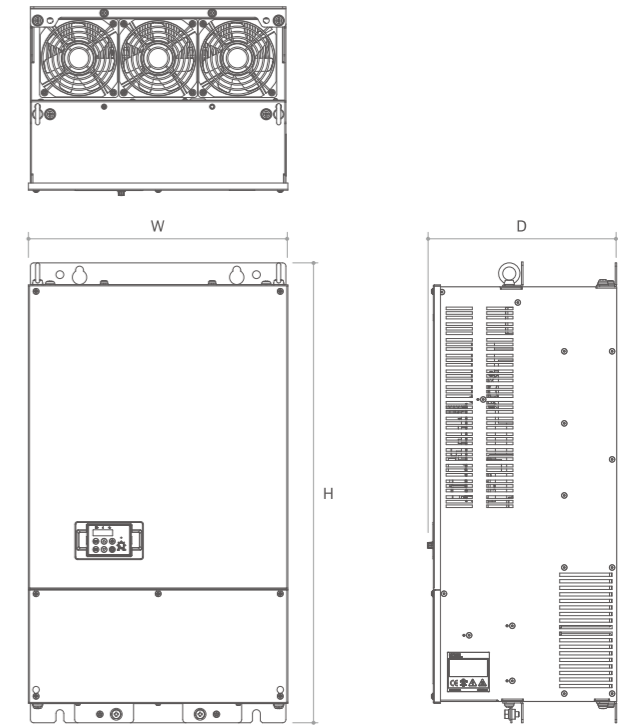

Frame	F9	F10
W [mm]	396	480
H [mm]	702	744
D [mm]	288	308
Weight [kg]	40.5	57.0

■ Controls

Item	Specification
Control Mode	V/F Control, User V/F, Enhanced sensorless vector control
Frequency Setting Range	0.01 to 400Hz
Frequency Tolerance	Digital Reference : ±0.01% Analog Reference : ±0.1%
Frequency Setting Resolution	Digital Command : 0.01 Hz Analog Command : 0.03 Hz / 60 Hz
Output Frequency Resolution	0.01 Hz
Frequency Setting	0~10 [V], 4~20 [mA], Keypad
Carrier Frequency	1~10kHz (default ND : 3kHz, HD : 5kHz)
ACC/DEC Time	0.1~3000sec (linear , S curve, U curve)
Starting Torque	100% / 3 Hz (V/f) 200% / 1 Hz (SLV)

Item	Specification	
Protective Function	Overcurrent	Exceeds internal over current trip level
	Overload	150%(HD) ,120%(ND) 60s
	Overvoltage	200V Class:410 V / 400V Class:820 V
	Low voltage	200V Class:190 V / 400V Class:380 V
	Heat sink overheat	NTC on IGBT
	Stall Prevention	Stall prevention during acceleration
	Ground Fault	Protection by electric circuit
Environment	Area of Use	Indoor
	Ambient Temperature	HD : -10 to 50°C / ND : -10 to 40°C
	Humidity	95% RH or less (no condensation)
	Storage Temperature	-20 to 60°C
	Altitude	Up to 1000 m
	Vibration	10Hz~20Hz 1G, 20Hz~55Hz 0.6G
Standard	UL 508C, EN61800-3 C3(2004/108/EC) EN61800-5-2, IEC6158:SIL 3	
Protective Design	Open IP20	

■ Keypad

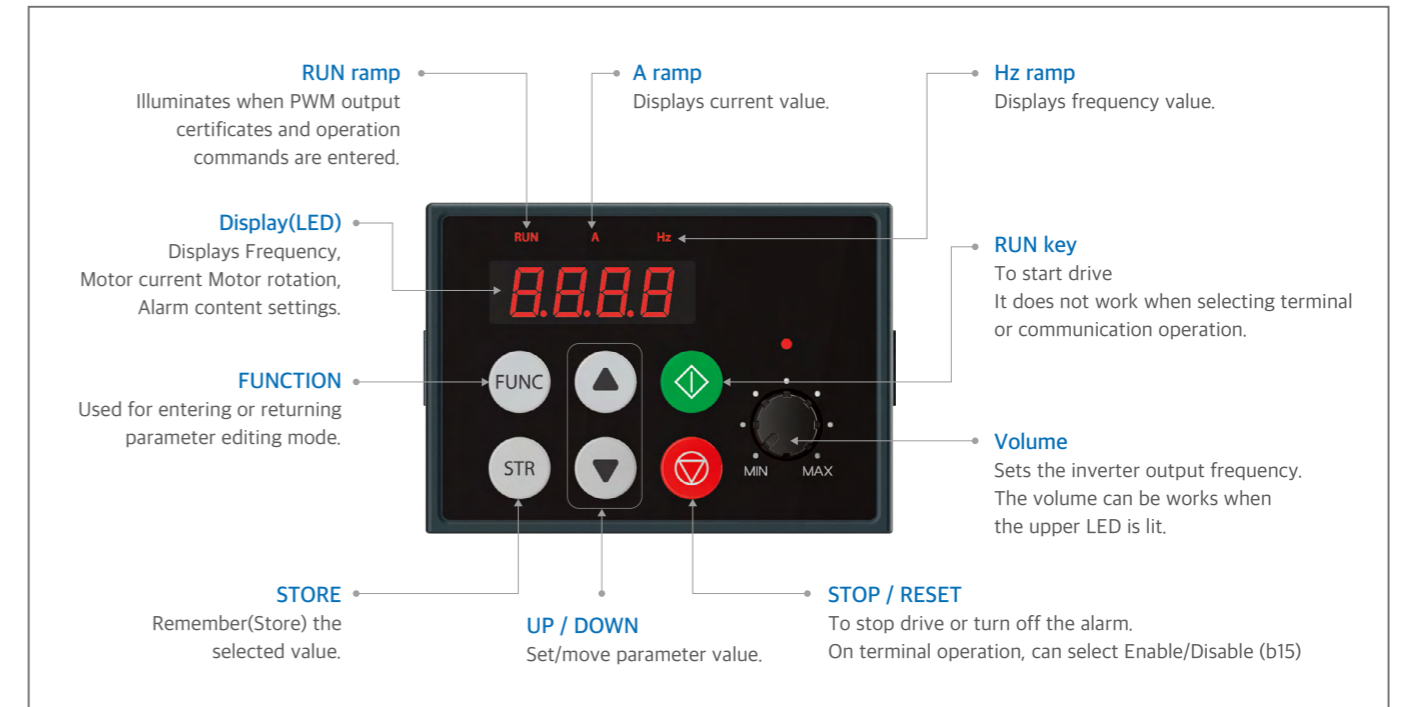

■ Removable Keypad

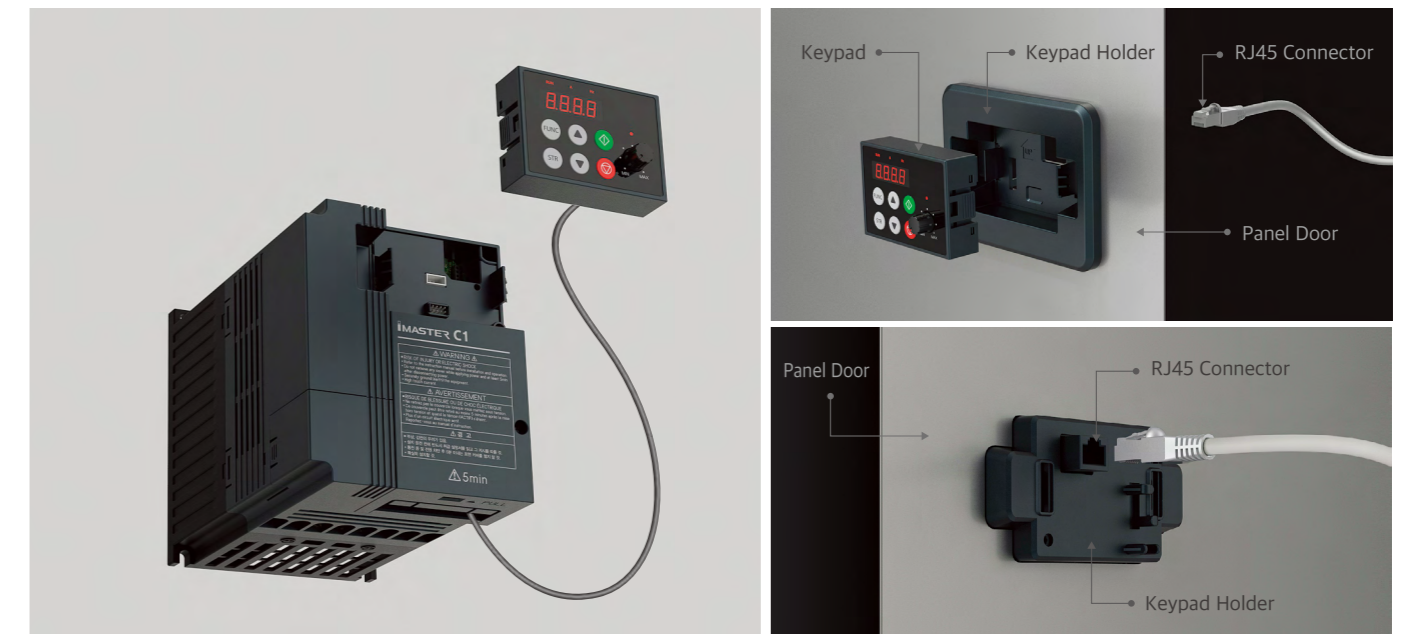

• Keypad holder order code

Order code	CPO-KEYPADHOLDER
Spec사 양	iMASTER C1 - Keypad Holder



■ Diagram

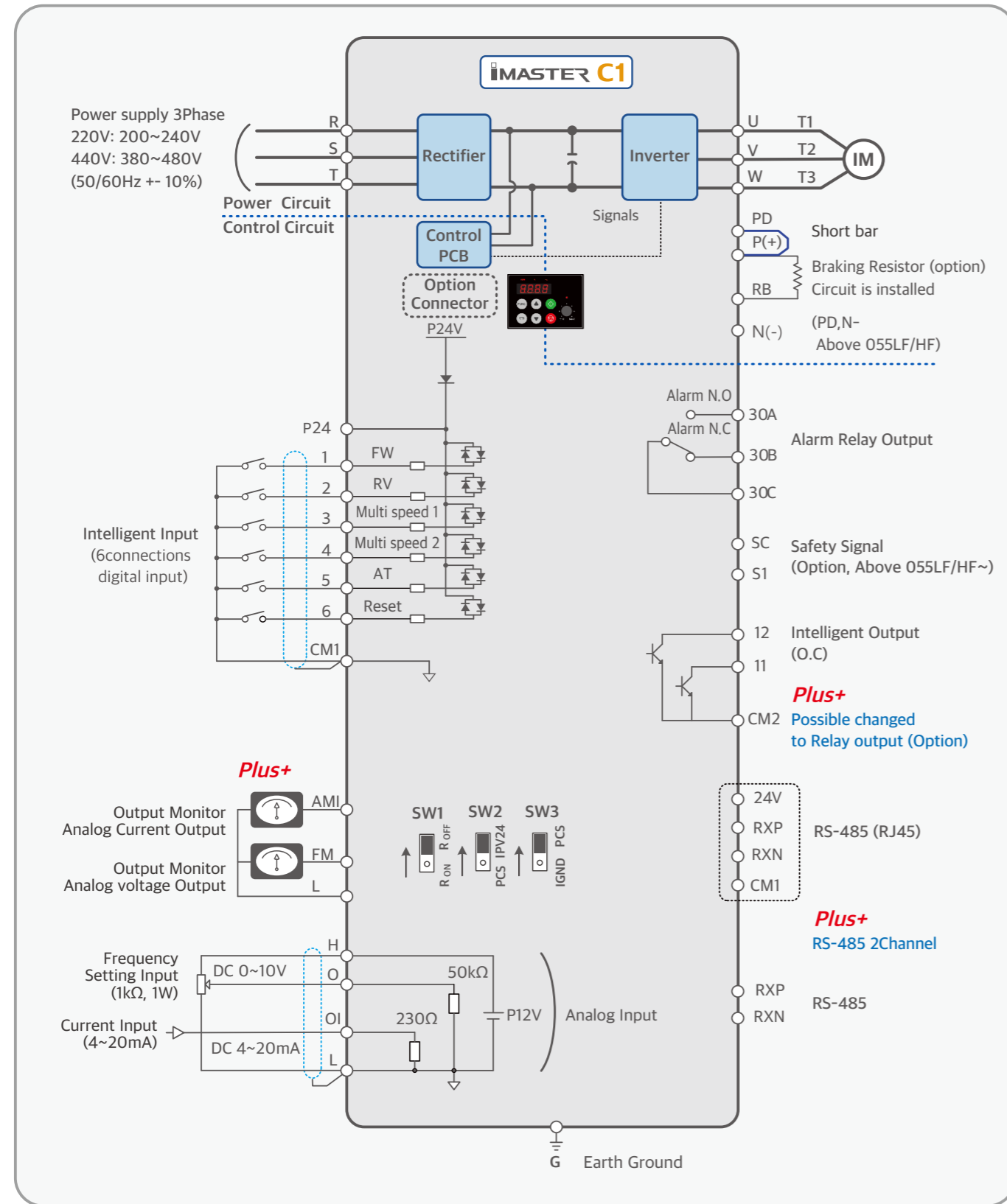

■ Control Circuit Terminal

Control Circuit Terminal

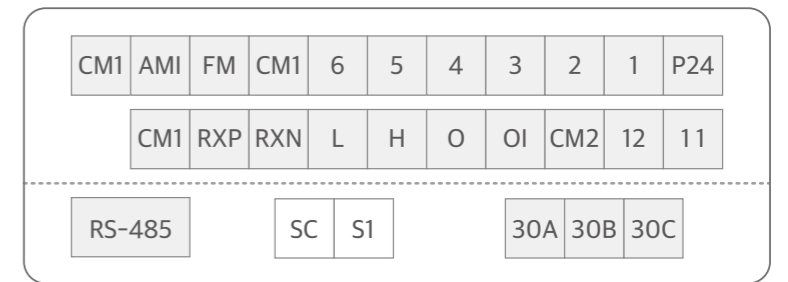

Terminal Symbols	Terminal Name	Specification	Remark
1~6	Intelligent Input Terminal	Min. on time: 12ms	
P24	Intelligent Input Terminal Power	24VDC±15%, 100mA	Refer to Diagram
CM1	Common Terminal for Input	-	
11, 12	Intelligent Output Terminal (O,C)	24VDC, 50mA MAX	Relay Output Changeable (Conversion Board-Optional)
CM2	Common Terminal for Output	-	
30A, 30B, 30C	Alarm Relay Output Terminal	30A(NO),30B(NC),30C(Comm.)	Refer to Diagram
H, O, OI, L	Frequency Command Terminal (V,A)	H(+10V), O(0~10V), OI(4~20mA), L(-)	
FM, AMI, L	Analog Monitor Terminal	FM(0~10V), AMI(4~20mA), L(-)	FM (Output Frequency) AM (Output Current)
RJ45, RXP, RXN	RS-485 Communication Terminal	No. 1 Channel (RJ 45) No. 2 Channel (RXP, RXN)	
S1, SC	Safety Signal Input Terminal	S1(Contact Input), SC(Comm.)	Above 5.5kW ~

■ Main Circuit Terminal

Main Circuit Terminal

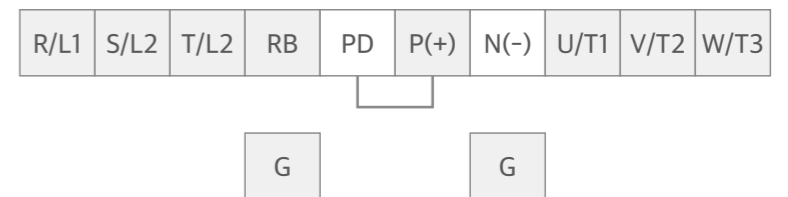

Terminal Symbols	Terminal Name	Function
R,S,T	Main Power Terminal	Connect input power
U,V,W	Inverter Output Terminal	Connect 3Phase motor
PD,P	DC Reactor Connection Terminal	Remove the short bar between PD and P and Connect DC Reactor (Above 5.5kW~)
P, RB	External Braking Resistor Connection Terminal	Connect Braking Resistor (Option)
P, N	External Braking Unit Connection Terminal	Connect Braking Unit (Option, Above 5.5kW~)
G	Earth Ground	Ground the inverter for prevention of electric shock

Strong torque performance

Stronger than or equal to competitors in terms of strong low-speed torque performance, high torque performance in all areas.

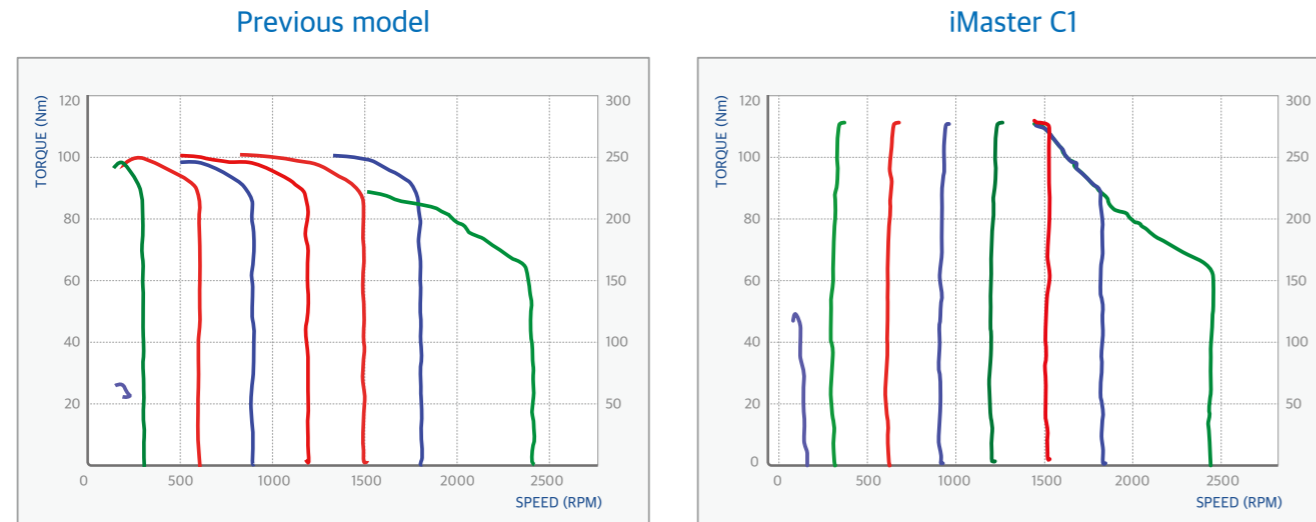

Overvoltage Limit Performance (regeneration avoidance)

In the case of regular occurrence of regeneration load, it is possible to increase the output frequency of motor in regeneration zone and control DC link voltage rise.

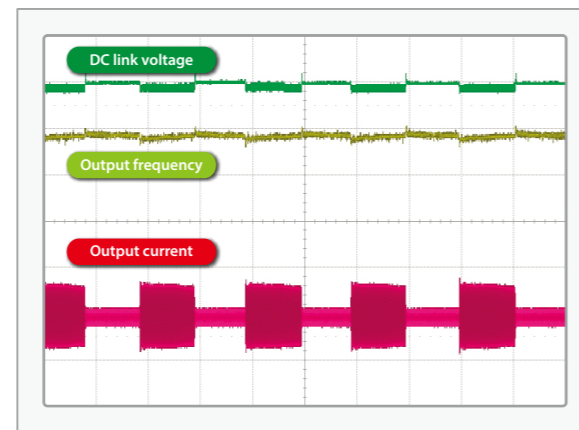

Overcurrent Limit Performance

Even in the case of step load, it is possible to control output current smoothly and keep output frequency constantly.

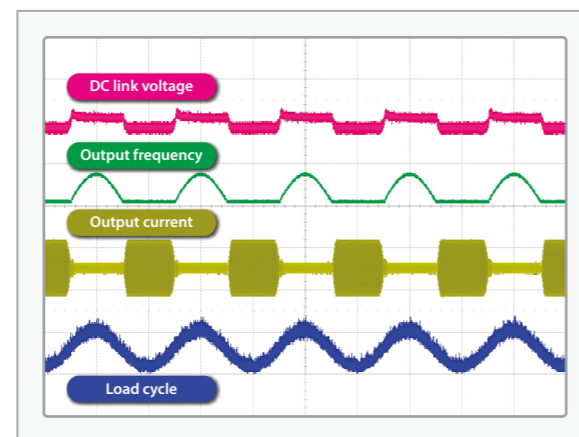

External Brake Control Function (for Lift)

When using external brakes, such as the lift system, it provides safe and elaborated control for all variables, and the operation speed can be changed depending on the load.

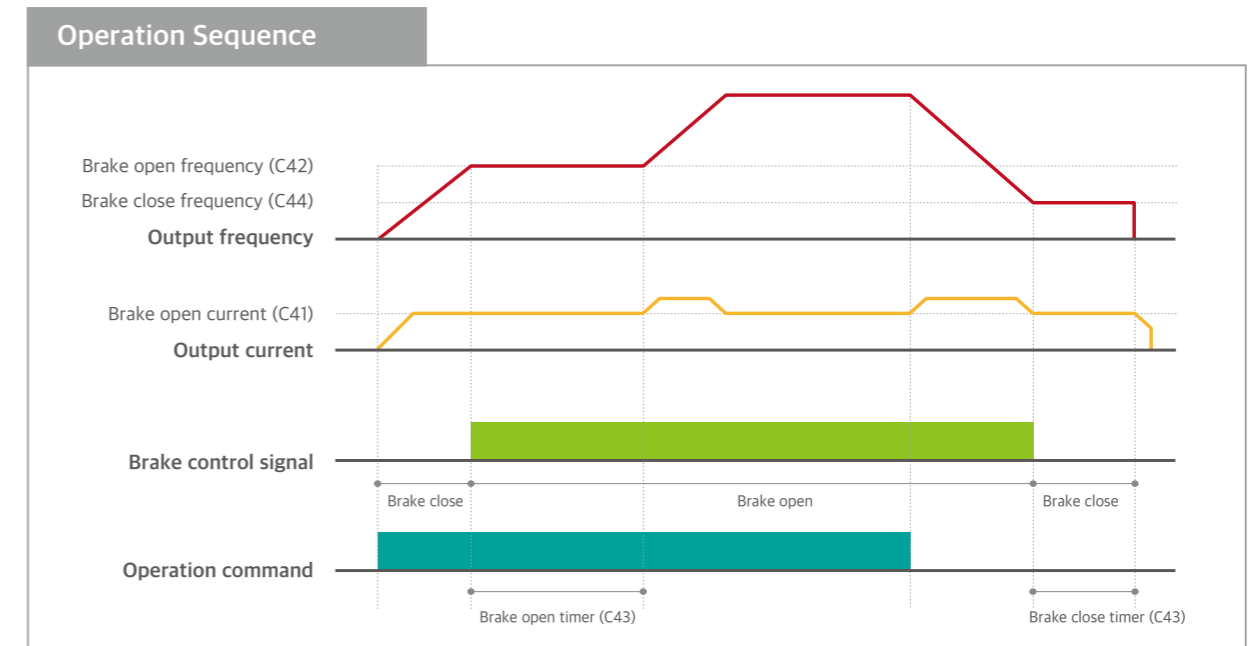

KEB (Kinetic Energy Buffering) function

The KEB function maintains the DC voltage by control the inverter speed during the power failure period, thereby helping maintain the interval between the instantaneous outage and the low voltage trip for a longer time.

The KEB function helps to keep user's facilities safe from any power failure situation.

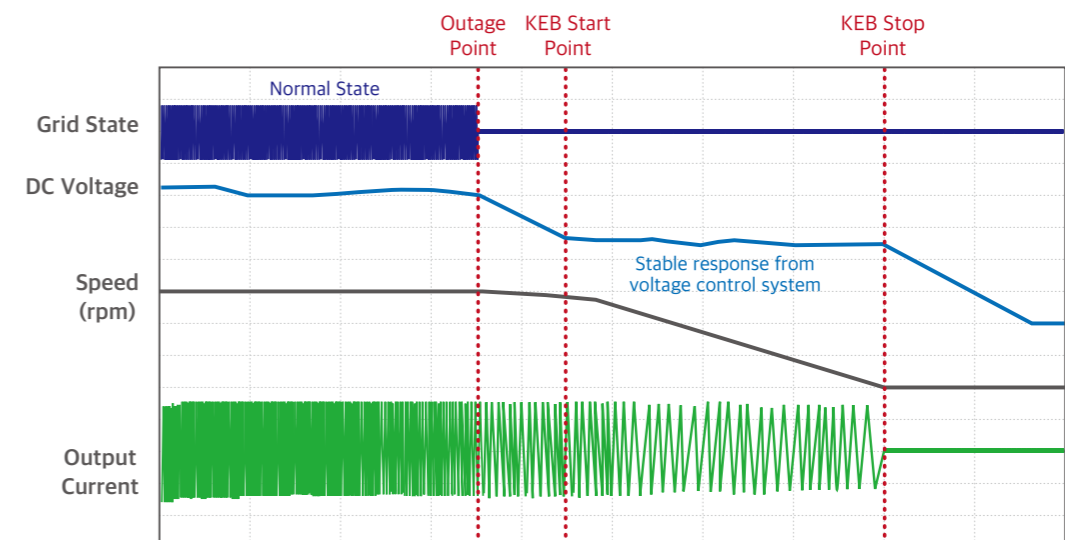

■ RS-485 Communication (2 Channel)

Two channels of Modbus RS-485 communications provide two-way multiple access and multiple inverters integrated operation and monitoring with minimal control wiring and cost savings.

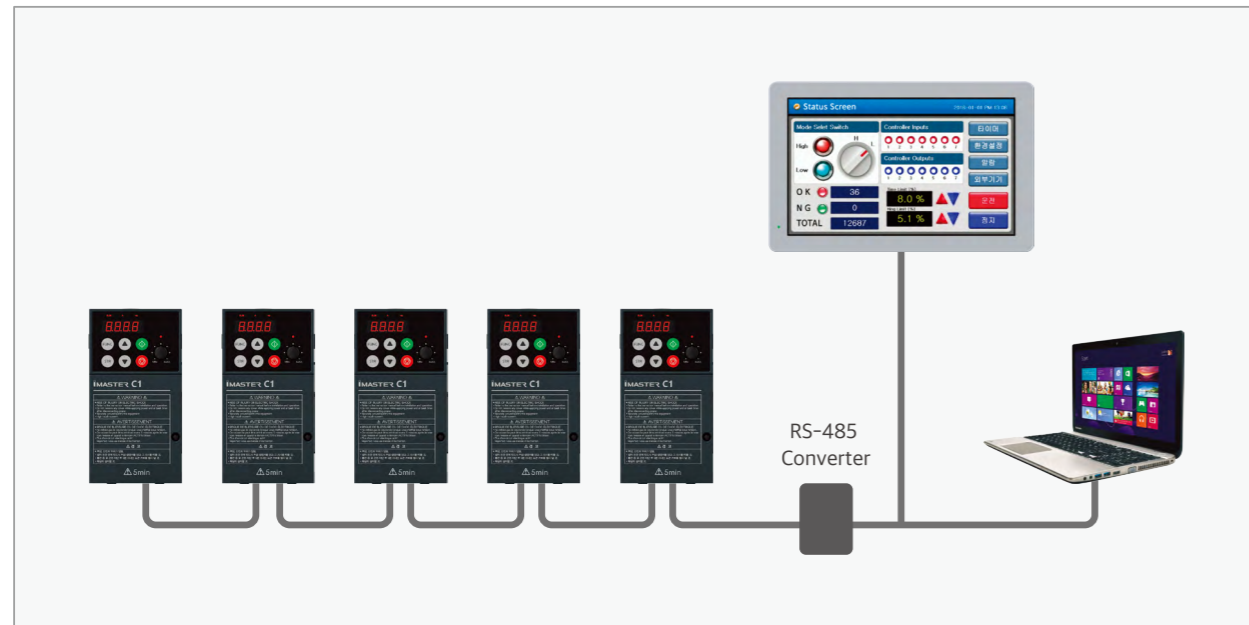

■ Extended Cooling Fan Life

The cooling fan on/off function allows more efficient use of the cooling fan. This feature helps you take longer cooling fan replacement cycles than before.



■ User V/F

User can randomly set the required V/F ratio according to the motor. User can use following parameters to obtain a suitable V/F pattern for a special motor.

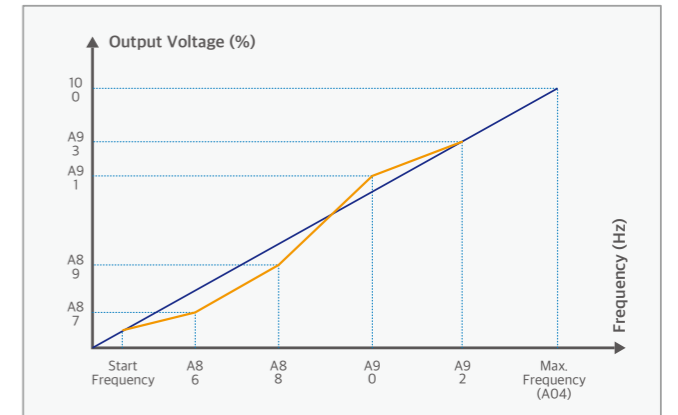

■ Droop Control

To drive the same load, the product responds to the torque change in each of multiple motors to control a speed and to enable each motor to keep an even load.

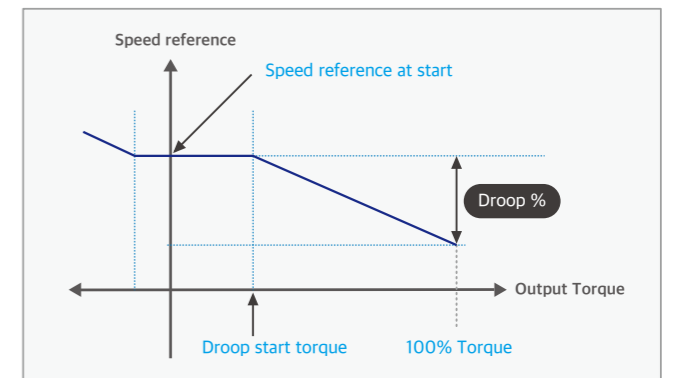

[Load balancing by droop control]

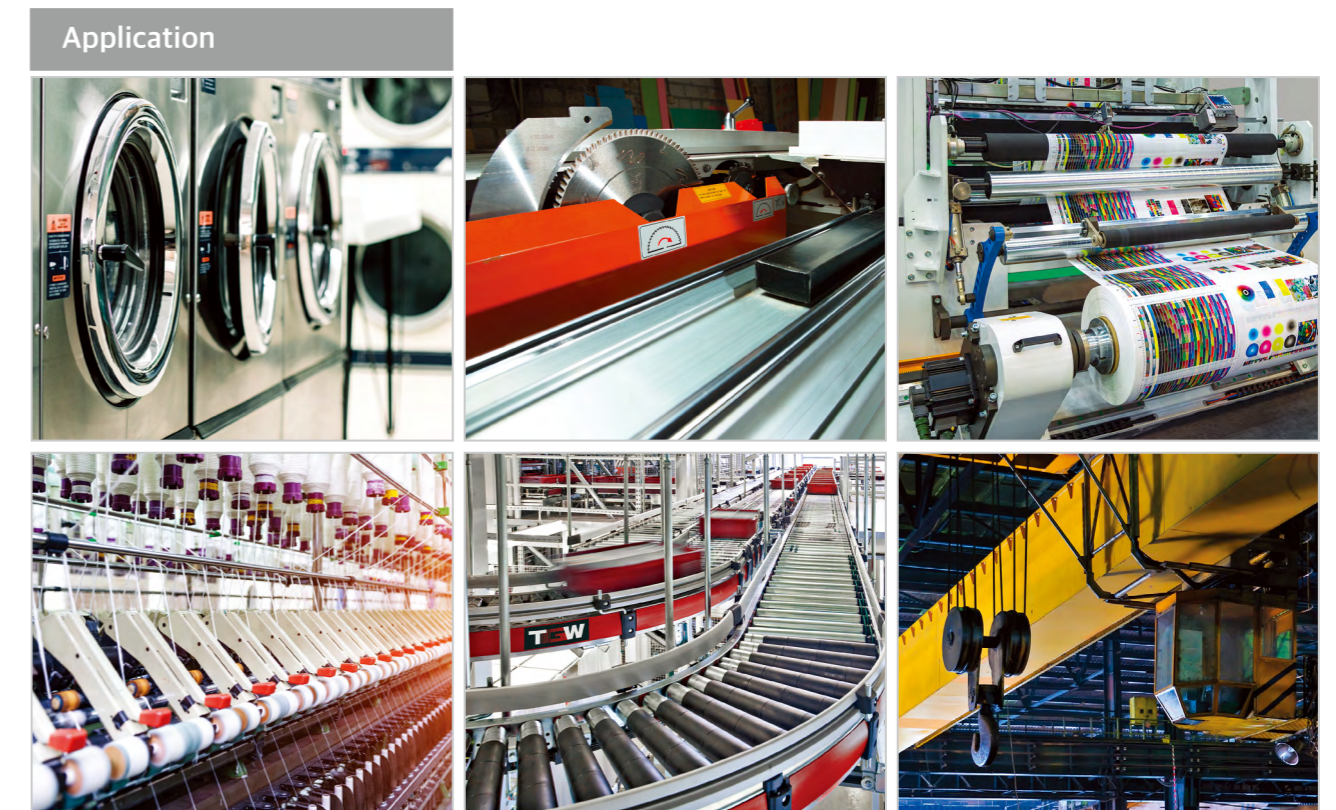

■ Protective Function 1

Name	Cause(s)	Error code
Overcurrent protection	When the inverter output current exceeds the rated current during the motor locked or reduced in speed. Protection circuit activates, halting inverter output.	E04
Overload protection	When the inverter output current causes the motor to overload, the electronic thermal trip in the inverter cuts off the inverter output.	E05
Overvoltage protection	If regenerative energy from the motor or the main power supply voltage is high, the protective circuit activates to cut off the inverter output when the voltage of DC link exceeds the specification.	E07
Communication error	Communication error between inverter and its operator. If the Reset signal persists for more than 4 seconds, it will occur.	E60
Under-voltage protection	When input voltage drops below the low-voltage detection level, the control circuit does not function normally. It will cause of overheat of motor and lack of torque that is why if receiving voltage is under 150~160V (200V class) or 300~320V (400V class), the inverter output is cut off.	E09
Output short-circuit	The inverter output was short-circuited. This condition causes excessive current for the inverter that is why, the inverter output is turned off.	E04 or E34
USP error	The USP error is indicated when the power is turned on with the Inverter in RUN state. (Enabled when the USP function selected)	E13
External trip	When the external equipment or unit has an error, the inverter receives the corresponding signal and cuts off the output.	E12
Temperature trip	When the temperature in the main circuit increases due to cooling fan stop, the inverter output is cut off.	E21
Inverter overload	The power device IGBT is protected from over heat. The operating time of inverter is 1 minute with 150% load of HD or 120% load of ND. The operating time is changed depending on carrier frequency, load, ambient temperature and power rating.	E17
Input phase loss	A function that detects phase loss in the input AC source to prevent damages.	E20
Braking resistor overload protection	When BRD exceeds the usage ratio of the regenerative braking resistor, the over-voltage circuit activates and the inverter output is switched off.	E06
OVS fail	The OVS output frequency is higher than maximum OVS output frequency during the setting time when the OVS function is enabled.	E02
CPU error	It occurred it has error between inverter logic board and I/O board or communication error occurred. Turn off inverter completely, check there is any connection losses then power on.	E11
Ground fault	When ground fault is detected on running condition, the output is cut off.	E14

■ Protective Function 2

Name	Cause(s)	Error code
EEPROM	The inverter output is cut off when EEPROM in the inverter has an error due to external noise, excessive temperature rise, or other factors. If the error is occurred, please check setting data again. If error is occurred when power-on and does not off, please turn off the inverter at least 10minutes and power on again.	E08
System overload detection fault	The output current of the drive is greater than the detection level set for this feature when it is enabled.	E23
System underload detection fault	The output current of the drive is less than the detection level set for this feature when it is enabled.	E24
FAN fault	The Fan fault is occurred, inverter output is cut off.	E33
Profibus fault (Option)	ProfibusDP optional card only. Host disconnection, or invalid host setting cause this error.	E40
DeviceNet fault (Option)	DeviceNet optional card only. Communication cable power loss, disconnect to host, or invalid host setting cause this error.	E41
HW Power fault 1	It occurred when inverter internal power is problem. Turn off power completely and try power on again.	E50
HW Power fault 2	It occurred when inverter internal power is problem. Turn off power completely and try power on again.	E51
Keypad fault	It occurred keypad communication error. Turn off power completely and try power on again.	E61
External trip 2	When the external equipment or unit has an error, the inverter receives the corresponding signal and cuts off the output. (Need setting for intelligent input terminal)	EE2
External trip 3	When the external equipment or unit has an error, the inverter receives the corresponding signal and cuts off the output. (Need setting for intelligent input terminal)	EE3
External trip 4	When the external equipment or unit has an error, the inverter receives the corresponding signal and cuts off the output. (Need setting for intelligent input terminal)	EE4
External trip 5	When the external equipment or unit has an error, the inverter receives the corresponding signal and cuts off the output. (Need setting for intelligent input terminal)	EE5
External trip 6	When the external equipment or unit has an error, the inverter receives the corresponding signal and cuts off the output. (Need setting for intelligent input terminal)	EE6